

AgriXchange WP4

Use Case Geo-fertilizer



Use case geo-fertilizer

- Farmer performs (variable rate) fertilizing
- Requests application map from N-advice service provider, which requires:
 - parcel geometry (LPIS)
 - Soil data (service provider)
 - LAI map (service provider)
 - GIS/Agronomic model (service provider)
- Uses application map to fertilize his parcel
 - Export and load on farm machinery
 - Log and save process data



Drivers

- Efficient and cost effective farming
 - More with less
 - Technology is available
- Demand for sustainable production
 - Consumers
 - Retail
 - Government
- Legislative requirements
 - CAP
 - Food safety regulations



Use case scheme

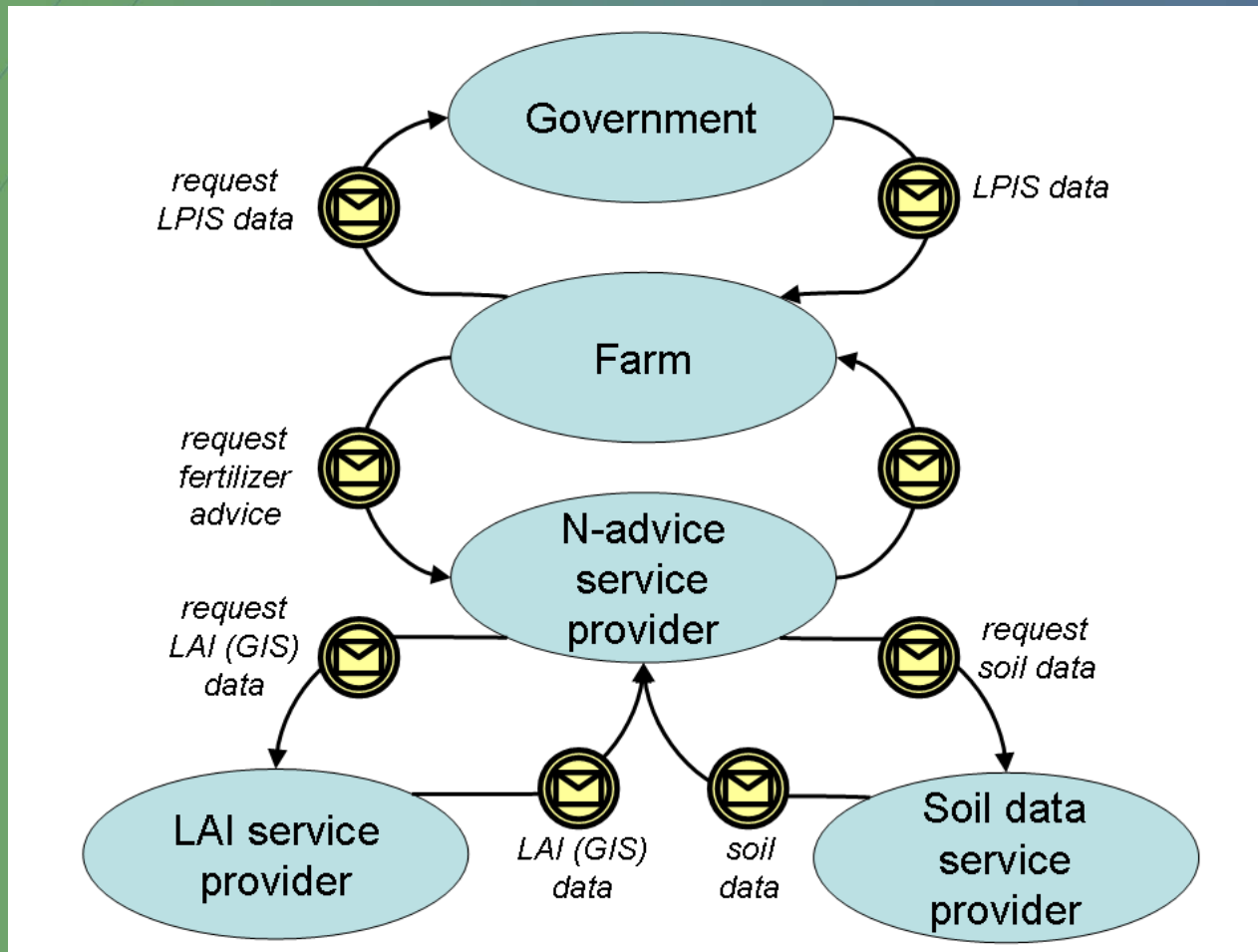

Parties involved

Actively involved parties

- Farmer
- Contractor
- Commercial service providers
- National or regional government

Other stakeholders

- Software developers
- Machine industry
- European Union
- Retail
- Consumers



Relevant standards

- ISO-11783 (ISOBUS)
 - AgroXML
 - EDI-Teelt
 - UN/Cefact
 - (E-)Daplos (?)
-
- However: different incompatible standards → adapters
 - No European standards available
 - Only partly support the full use case



Bottlenecks for harmonization

- No generally accepted standards at European level available for data exchange
- More commonly used standards in agriculture (e.g. UN/Cefact) focus on trade, logistics, tracking-tracing
- Commonly used standards are very limited in support of spatial data
- ISO-11783 still not fully implemented by machine vendors



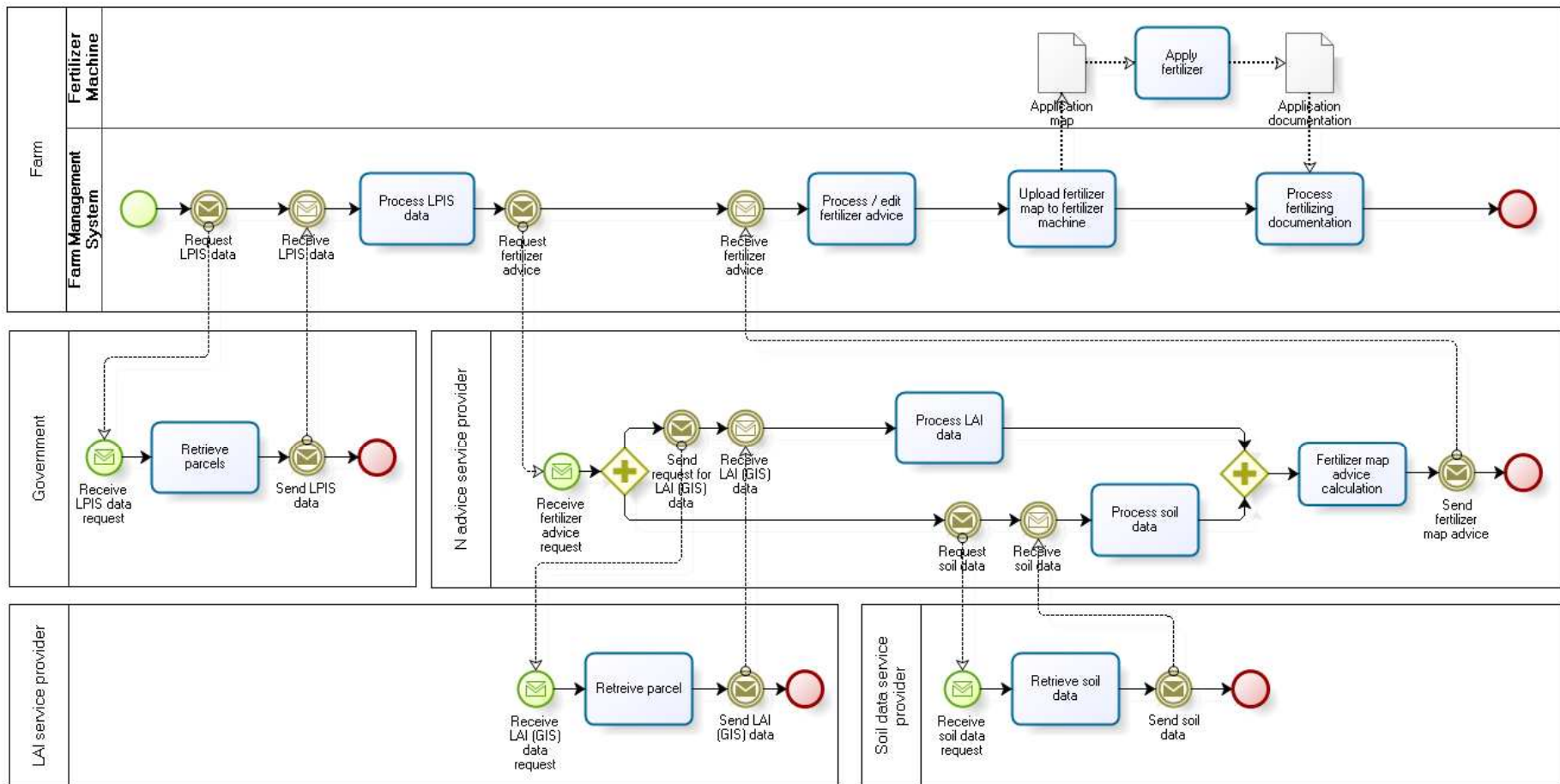

powered by
BizAgi Process Modeler



agriXchange
network for data exchange in agriculture